

## THE WHARF PHASE 2 STORMWATER MANAGEMENT NARRATIVE

THE WHARF PHASE 2 DEVELOPMENT INCLUDES TWO 2-STORY BELOW-GRADE GARAGES, 5 BUILDING PARCELS ON TOP OF THE GARAGES, MARITIME IMPROVEMENTS IN WASHINGTON CHANNEL INCLUDING 3 BUILDINGS, AND ASSOCIATED ROADWORK, SITEWORK, INFRASTRUCTURE, AND STORMWATER MANAGEMENT.

THE WHARF IS REQUIRED TO COMPLY WITH THE CURRENT DOEE STORMWATER MANAGEMENT (SWM) REGULATIONS FOR THE ANACOSTIA WATERFRONT DEVELOPMENT ZONE (AWDZ). THE AWDZ SWM REGULATIONS FOR PRIVATE PROPERTY REQUIRE 1.2" OF RUNOFF RETENTION AND 1.7" OF RUNOFF FILTRATION. DISTURBED PORTIONS OF PUBLIC SPACE WILL BE REQUIRED TO PROVIDE 1.2" OF RETENTION TO THE MAXIMUM EXTENT POSSIBLE. DUE TO THE PROJECT'S IMMEDIATE PROXIMITY TO THE WASHINGTON CHANNEL, PEAK STORMWATER FLOWRATE ATTENUATION ("QUANTITY CONTROL") SHOULD NOT BE REQUIRED.

THE PHASE 2 STORMWATER MANAGEMENT REQUIREMENTS WILL BE PREDOMINANTLY ACHIEVED THROUGH THE COLLECTION OF RUNOFF INTO SEVERAL LARGE STORMWATER CISTERNS LOCATED IN THE GARAGES. THESE CISTERNS WILL BE SIZED FOR THE 1.7" STORM EVENT, MEETING BOTH THE RETENTION AND FILTRATION REQUIREMENTS FOR NEARLY ALL OF THE PHASE 2 DEVELOPMENT. THE COLLECTED RUNOFF WILL BE TREATED FOR REUSE THROUGH BUILDING SYSTEMS.

THE PHASE 2 STORMWATER MANAGEMENT DESIGN WILL ALSO INCLUDE MULTIPLE LOW IMPACT DEVELOPMENT FEATURES SUCH AS GREEN ROOFS ON BUILDINGS AND THE GARAGE, PERVIOUS PAVEMENT, BIORETENTION, TREE PLANTING AND PRESERVATION, AND STRUCTURAL STORMWATER FILTERS. PUBLIC SPACE SWM FEATURES WILL INCLUDE BIORETENTION, BIOSWALES, PERVIOUS PAVEMENT, AND PERVIOUS FLEXIPAVE BIKE PATH.



CONSTRUCTION SPECIFICATION		
1. LENGTH - MIN. OF 50' RAMP x 30' RAMP FOR SINGLE RESIDENCE LOT.		
2. WIDTH - 10' MINIMUM, SHOULD BE PLACED AT THE EXISTING ROAD TO PROVIDE A TURNING RADIUS.		
3. GEOTEXTILE FABRIC (FILTER CLOTH) SHALL BE PLACED OVER THE EXISTING GROUND PRIOR TO PLACING STONE.		
4. STONE - CRUSHED AGGREGATE (2" TO 3") OR RECLAIMED OR RECYCLED CONCRETE EQUIVALENT SHALL BE PLACED AT LEAST 6" DEEP OVER THE LENGTH AND WIDTH OF THE ENTRANCE.		
5. SURFACE WATER - ALL SURFACE WATER FLOWING TO OR DIVERTED TOWARD CONSTRUCTION ENTRANCES SHALL BE PIPED THROUGH THE ENTRANCE, MAINTAINING POSITIVE DRAINAGE. PIPE INSTALLED THROUGH THE STABILIZED CONSTRUCTION ENTRANCE SHALL BE PROTECTED WITH A MOUNTABLE BERM WITH 3:1 SLOPES AND MAX. OF 4" OF STONE OVER THE PIPE. PIPE HAS TO BE SIZED ACCORDING TO THE DRAINAGE. WHEN THE SCE IS LOCATED AT A HIGH SPOT AND HAS NO DRAINAGE TO CONVEY, A PIPE WILL NOT BE NECESSARY. PIPE SHOULD BE SIZED ACCORDING TO THE AMOUNT OF RUNOFF TO BE CONVEYED. A 6" MIN. WILL BE REQUIRED.		
6. LOCATION - A STABILIZED CONSTRUCTION ENTRANCE SHALL BE LOCATED AT EVERY POINT WHERE CONSTRUCTION TRAFFIC ENTERS OR LEAVES A CONSTRUCTION SITE, VEHICLES LEAVING THE SITE MUST TRAVEL OVER THE ENTIRE LENGTH OF THE STABILIZED CONSTRUCTION ENTRANCE.		
7. MAINTENANCE - THE ENTRANCE SHALL BE MAINTAINED IN CONDITION WHICH WILL PREVENT TRACKING OR FLOWING OF SEDIMENT ONTO PUBLIC RIGHTS-OF-WAY. THIS MAY REQUIRE PERIODIC TOP DRESSING WITH ADDITIONAL STONE AS CONDITIONS DEMAND AND REPAIR AND/OR CLEANOUT OF ANY MEASURES USED TO TRAP SEDIMENT. ALL SEDIMENT SPILLED, DROPPED, WASHED OR TRACKED ONTO PUBLIC RIGHTS-OF-WAY MUST BE REMOVED IMMEDIATELY.		
8. WASHING - WHEELS SHALL BE CLEANED TO REMOVE SEDIMENT PRIOR TO ENTRANCE ONTO PUBLIC RIGHT-OF-WAY WHEN WASHING IS REQUIRED. IT SHALL BE DONE ON AN AREA STABILIZED WITH STONE WHICH DRAINS INTO AN APPROVED SEDIMENT TRAPPING DEVICE.		
9. PERIODIC INSPECTION AND NEEDED MAINTENANCE SHALL BE PROVIDED AFTER EACH RAIN.		

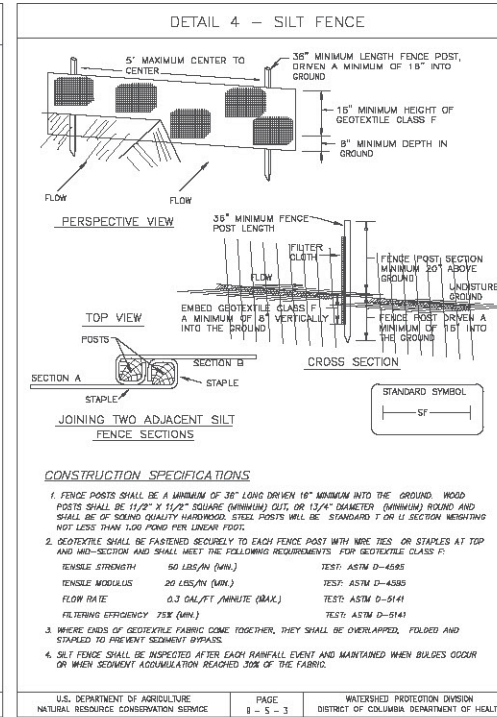
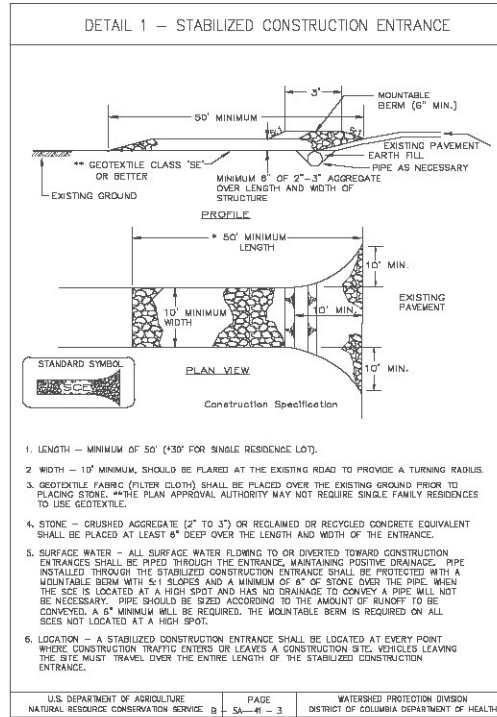

SILT FENCE		
Silt Fence Design Criteria		
Slope Steepness	(Maximum) Slope Length	(Maximum) Silt Fence Length
Flatter than 50:1	unlimited	unlimited
50:1 to 10:1	125 feet	1,000 feet
10:1 to 5:1	100 feet	750 feet
5:1 to 3:1	80 feet	500 feet
3:1 to 2:1	40 feet	250 feet
2:1 and steeper	20 feet	125 feet

Note: In areas of less than 2% slope and sandy soils (USDA general classification system, soil Class A) maximum slope length and silt fence length will be unlimited. In these areas a silt fence may be the only perimeter control required.

U.S. DEPARTMENT OF AGRICULTURE  
NATURAL RESOURCE CONSERVATION SERVICE | PAGE | WATERSHED PROTECTION DIVISION  
DISTRICT OF COLUMBIA DEPARTMENT OF HEALTH

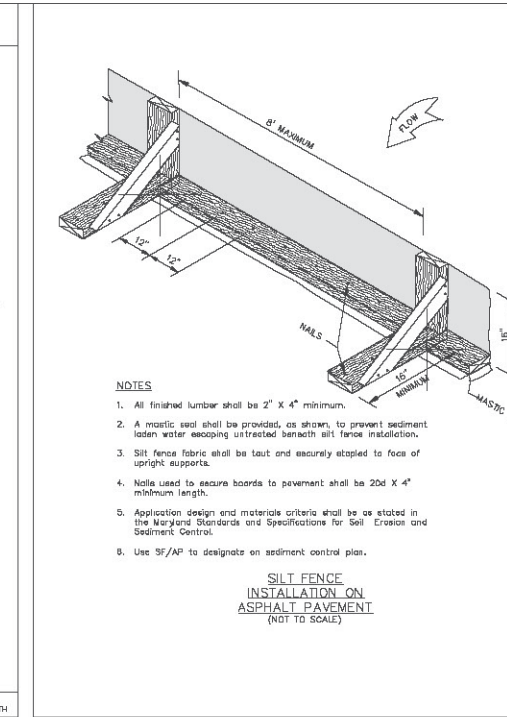

STANDARDS AND SPECIFICATIONS FOR DUST CONTROL		
1. THE CONTRACTOR SHALL CONDUCT OPERATIONS AND MAINTAIN THE PROTECTIVE SITE SO AS TO MINIMIZE THE CREATION AND DISPERSION OF DUST. DUST CONTROL SHALL BE USED THROUGHOUT THE WORK AT THE SITE.		
2. THE CONTRACTOR MUST PROVIDE CLEAN WATER, FREE FROM SALT, OIL AND OTHER DELETERIOUS MATERIAL TO BE USED FOR ON-SITE DUST CONTROL.		
3. THE CONTRACTOR SHALL SUPPLY WATER SPRAYING EQUIPMENT CAPABLE OF ACCESSING ALL WORK AREAS.		
4. THE CONTRACTOR SHALL IMPLEMENT STRICT DUST CONTROL MEASURES DURING ACTIVE CONSTRUCTION PERIODS ON-SITE. THESE CONTROL MEASURES WILL GENERALLY CONSIST OF WATER APPLICATIONS THAT SHALL BE APPLIED A MINIMUM OF ONCE PER DAY DURING DRY WEATHER OR MORE OFTEN AS REQUIRED TO PREVENT DUST EMISSIONS.		
5. FOR WATER APPLICATION TO UNDISTURBED SOIL SURFACES, THE CONTRACTOR SHALL:		
A. APPLY WATER WITH EQUIPMENT CONSISTING OF TANK, SPRAY BAR, PUMP WITH DISCHARGE PRESSURE GAUGE.		
B. ARRANGE SPRAY BAR HEIGHT, NOZZLE SPACING AND SPRAY PATTERN TO PROVIDE COMPLETE COVERAGE OF GROUND WITH WATER.		
C. DISPENSE WATER THROUGH NOZZLES ON SPRAY BAR AT 20 PSI, MINIMUM. KEEP AREAS DAMP WITHOUT CREATING NUISANCE CONDITIONS SUCH AS PONDING.		
6. FOR WATER APPLICATION TO SOIL SURFACES DURING DEMOLITION AND/OR EXCAVATION, THE CONTRACTOR SHALL:		
A. APPLY WATER WITH EQUIPMENT CONSISTING OF A TANK, PUMP WITH DISCHARGE GAUGE, HOSES AND MIST NOZZLES.		
B. LOCATE TANK AND SPRAYING EQUIPMENT SO THAT THE ENTIRE EXCAVATION AREA CAN BE MISTED WITHOUT INTERFERING WITH DEMOLITION AND/OR EXCAVATION EQUIPMENT OR OPERATIONS. KEEP AREAS DAMP WITHOUT CREATING NUISANCE CONDITIONS SUCH AS PONDING.		
C. APPLY WATER SPRAY IN A MANNER TO PREVENT MOVEMENT OF SPRAY BEYOND THE SITE BOUNDARIES.		

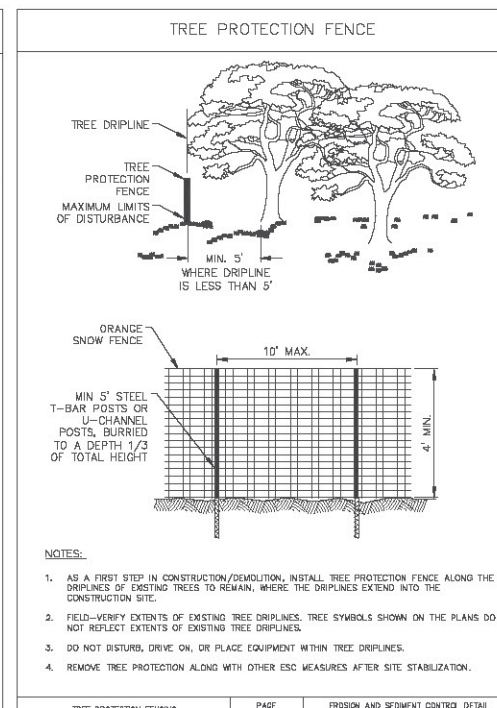
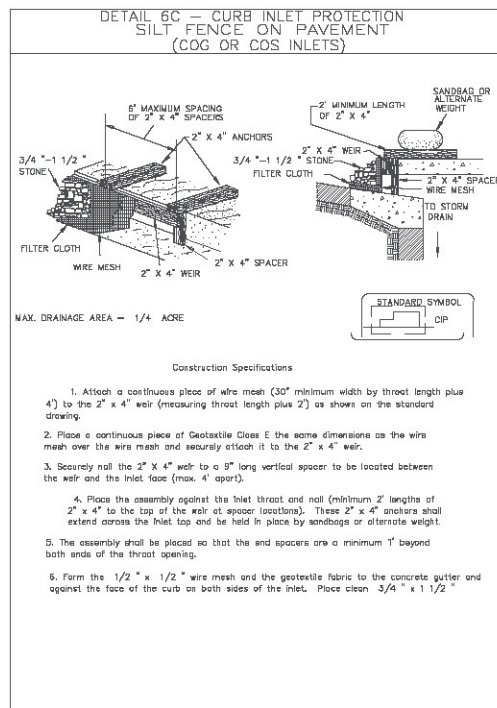

SILT BAG FOR PUMPED DIRTY WATER			
I. INSTALLATION/USE			
1. UNFOLD THE SILT BAG AND SIT INSIDE THE FABRICATED BOX (WOOD, METAL, OR PLASTIC).			
2. INSERT PUMP DISCHARGE HOSE INTO HANDY SEWN-IN SPOUT AND SECURE WITH THE ATTACHED STRAPS.			
3. CONNECT OUTFALL PIPE OR HOSE TO THE OUTLET PIPE OF BOX AND RUN TO THE NEAREST CATCH BASIN.			
4. PUMP DIRTY WATER INTO BAG. THE BAG COLLECTS THE SILT AS THE CLEAN WATER GENTLY FILTERS OUT FROM ALL SIDES.			
II. SPECIFICATIONS FOR SILT BAG 10'x15', 12'-1/2'x15', AND 15'x15' SIZES.			
III. MAINTENANCE			
1. REPLACE THE SILT BAG AFTER IT IS FILLED WITH SILT.			
PROPERTIES	TEST METHOD	UNITS	WOVEN
WEIGHT	ASTM D-3776	OZ./YD.	8
CRAB TENSIL	ASTM D-4632	LBS.	300
PUNCTURE	ASTM D-4633	LBS.	120
FLOW RATE	ASTM D-4491	GAL./MIN./FT <sup>2</sup>	40
PERMITIVITY	ASTM D-4991	%	0.55
UV RESISTANCE	ASTM D-4355	%	80

U.S. DEPARTMENT OF AGRICULTURE  
NATURAL RESOURCE CONSERVATION SERVICE | PAGE | WATERSHED PROTECTION DIVISION  
DISTRICT OF COLUMBIA DEPARTMENT OF HEALTH

**SOUTHWEST WATERFRONT PHASE 2 SEDIMENT CONTROL NARRATIVE**

PHASE 2 IS LOCATED WITHIN AND IS A PART OF A LARGER DEVELOPMENT SUBMITTED UNDER SEPARATE PLANS KNOWN AS "THE WHARF". THE PHASES SHOWN ARE FOR THE INITIAL AND INTERMEDIATE CONDITION, BEFORE BMPs HAVE BEEN INSTALLED. THE SITE WILL UNDERGO UTILITY TRENCHING, UTILITY ABANDONMENT AND INSTALLATION, ROADWORK, SURFACE IMPROVEMENTS, GRADING, UNDERGROUND PARKING, ASPHALT DIGGING, CONCRETE WALL DEMOLITION, MILL AND OVERLAY OF MAINE AVE SW NORTHBOUND AND PAVING OF MAINE AVE SOUTHBOUND. MEASURES THAT WILL BE TAKEN FOR THE SEDIMENT CONTROL PLAN WILL INCLUDE SILT FENCE, SUPER SILT FENCE, INLET PROTECTION, CURB INLET PROTECTION, STONE CONSTRUCTION ENTRANCES, AND TREE PROTECTION AROUND SELECT TREES.

PHASE 2 IS LOCATED BETWEEN MAINE AVENUE SW AND THE WASHINGTON CHANNEL, EAST OF 7TH STREET PARK AND WEST OF PARCEL 11/WATERFRONT PARK. THE PHASE 2 BUILDING2 IS LOCATED ON TOP OF A 2-LEVEL UNDERGROUND PARKING GARAGE.

BECAUSE ALL SURROUNDING INFRASTRUCTURE WILL HAVE BEEN INSTALLED PRIOR TO THE ONSET OF PHASE 2 BUILDING CONSTRUCTION, THE MAJORITY OF THE SITE WILL BE STABILIZED AND SEDIMENT CONTROL WILL ALREADY BE IN PLACE. NEVERTHELESS, ALL SEDIMENT-LADEN RUNOFF FROM THE CONSTRUCTION SITE MUST NOT LEAVE THE WHARF BEFORE BEING FILTERED AND PERIMETER CONTROLS MUST BE INSTALLED AND MAINTAINED.

A RESPONSIBLE PERSON MUST BE PRESENT OR AVAILABLE WHILE THE SITE IS IN A LAND-DISTURBING PHASE. THE RESPONSIBLE PERSON IS CHARGED WITH BEING AVAILABLE TO (A) INSPECT THE SITE AND ITS ESC MEASURES AT LEAST ONCE BIWEEKLY AND AFTER A RAINFALL EVENT TO IDENTIFY AND REMEDY EACH POTENTIAL OR ACTUAL EROSION PROBLEM, (B) RESPOND TO EACH POTENTIAL OR ACTUAL EROSION PROBLEM IDENTIFIED BY CONSTRUCTION PERSONNEL, AND (C) SPEAK ON SITE WITH DDOE TO REMEDY EACH POTENTIAL OR ACTUAL EROSION PROBLEM. A RESPONSIBLE PERSON SHALL BE (A) LICENSED IN THE DISTRICT OF COLUMBIA AS A CIVIL OR GEOTECHNICAL ENGINEER, A LAND SURVEYOR, OR ARCHITECT; OR (B) CERTIFIED THROUGH A TRAINING PROGRAM THAT DDOE APPROVES, INCLUDING A COURSE ON EROSION CONTROL PROVIDED BY ANOTHER JURISDICTION OR PROFESSIONAL ASSOCIATION. DURING CONSTRUCTION, THE RESPONSIBLE PERSON SHALL KEEP ON SITE PROOF OF PROFESSIONAL LICENSING OR OF SUCCESSFUL COMPLETION OF A DDOE-APPROVED TRAINING PROGRAM. [21 DCMR § 547]

STANDARDS AND SPECIFICATIONS FOR STREET SWEEPING		
1. STREETS WITHIN ONE MILE SHALL BE INSPECTED DAILY, ANY DROPPED SOIL, DUST AND/OR DEBRIS SHALL BE REMOVED.		
2. VACUUM TYPE STREET CLEANER SHALL BE USED TO EFFECTIVELY REMOVE TOTAL DUST AND DIRT ON PAVED SURFACES.		
3. ROADS SHALL BE SWEEP ON A WEEKLY BASIS (MINIMUM) DURING ALL ON AND OFF SITE HAULING OPERATIONS FOR UP TO ONE MILE ALONG HAUL ROUTES.		

